

# G85 G86

(Large Display Counter) (Large Display)

## SERIES



- LARGE RED LED DISPLAY
- DECIMAL POINT POSITION SETTING
- MINUS DISPLAY POSSIBLE
- FREE WRIGHT FEATURE
- SINGLE/DOUBLE SIDE DISPLAY
- MODULAR DESIGN(UPTO 4LEVELS DISPLAY)

### MODEL SELECTION

MODEL	NO. OF DIGITS	NO. OF DISPLAY	FEATURES		CASE SIZE	WEIGHT (KG.)	
			MINUS DISPLAY	FREE WRIGHT			
G85- 101	4	SINGLE SIDE			S	6.7	
102			○				
103				○			
104			○	○			
201	5	SINGLE SIDE			L	7.5	
202			○		S	6.7	
203				○		L	7.5
204			○	○			
301	6	SINGLE SIDE			L	7.5	
303				○			
111	4	DOUBLE SIDE			S	7.1	
112			○				
113				○			
114			○	○			
211	5	DOUBLE SIDE			L	8.0	
212			○		S	7.5	
213				○		L	8.0
214			○	○			
311	6	DOUBLE SIDE			L	8.0	
313				○			
G86- 105	4	SINGLE SIDE	BCD INPUT DISPLAY		S	6.7	
205	5				L	7.5	
305	6				S	7.1	
115	4	DOUBLE SIDE			L	8.0	
215	5				S	7.1	
315	6				L	8.0	

### MULTI-LEVEL DISPLAY CONFIGURATION(from Top(1st)to Bottom(4th))

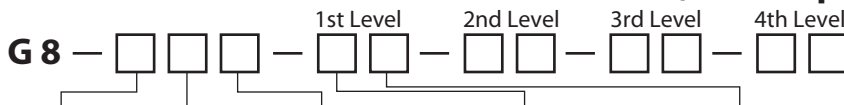

Case Size	Display	Levels
S	1 Single	1 2 Levels
L	2 Double	2 3 Levels
		3 4 Levels

Digits	Type
4 4 Digits	1 Total counter
5 5 Digits	2 Total counter (w/Minus sign)
	3 Total counter (w/Free Write)
6 6 Digits	4 Total counter (w/Minus sign, Free Write)
	5 Display only

Notes:

- Combination of S and L cases not possible.
- Unit cost and shipping costs will vary according to customer's configuration. Please contact our Sales Department to request for an exact quotation.

## INITIALIZATION

Below is the guide to set the following:

Input (90° Quadrature or Add / Subtract (Individual), Decimal Point Position, BCD Input Logic (Positive / Negative) , Minus (-) Sign Display Selection.



This is done by setting the correct position of the Terminal Jumpers ( OPEN or CLOSE ) which can be found on the internal Main PCB of the unit.

Refer to Figures 1 & 2 to the right for the location of Terminal Jumpers.



Make sure to wait at least 1 minute after disconnecting the power of the unit before touching or making changes to the Terminal Jumper positions.

### Terminal Jumpers Setting Guide

MODEL		OPEN 	CLOSE 
G 85	DP1	No Decimal Point	0.0
	DP2		0.00
	DP3		0.000
	SW1	Add / Subtract (Individual) Input	90° Quadrature Input
	SW2	*SW2 Open, SW3 Close : Minus(-) sign displays after reset.	
	SW3	*SW2 Open, SW3 Open : Minus(-) sign does not display after reset.	
	SW4	*Negative Logic (BCD Input)	*Positive Logic (BCD Input)
G 86	DP1	No Decimal Point	0.0
	DP2		0.00
	DP3		0.000
	SW1	Negative Logic (BCD Input)	Positive Logic (BCD Input)

\*For models with Free Write feature only

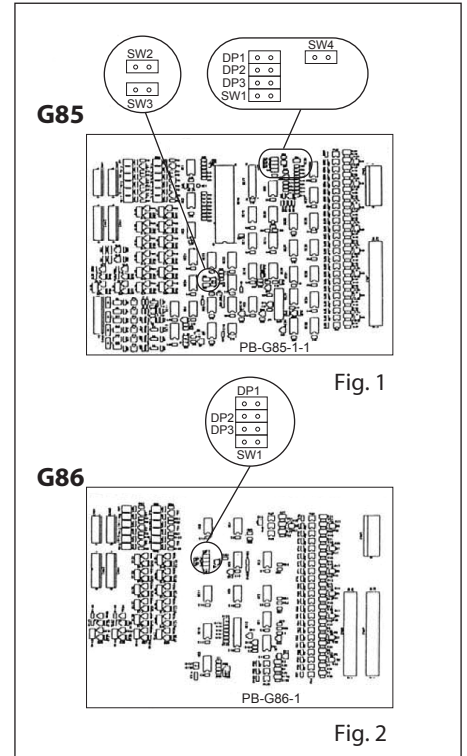

## SPECIFICATIONS

ITEM	G85-101	102	103	104	111	112	113	114	201	202	203	204	211	212	213	214	301	303	311	313
Display	Red LED 101.6(H) x 60.0(W) mm Zero Suppressing																			
No.of Digits	4								5								6			
Power	AC100~240V -15% / 10% 50/60Hz																			
Input	Non-Contact Input : Open Collector Transistor Input (Sink Current 7mA) L : 0 - 2V H : 4 - 30V Voltage Input : Input Impedance 1.5KΩ L : 0 - 8V H : 10 - 30V Contact Input : Relay, Microswitch, etc.(Sink Current 7mA)																			
Connection	Input : Terminal Screw Power : Terminal Screw Free Write : Amphenol Connector																			
Decimal Point	0.0/0.00/0.000																			
Count Speed	Non-contact : 1kHz Contact : 20Hz																			
Input Type	90°Quadrature Input Add/Subtract(Individual)																			
Pulse Width	Non-Contact : 500μsec Contact : 25ms (Make 1:1)																			
Count Range	-9999 - 9999 (101,103,111,113 : 0 - 9999)								-99999 - 99999 ( 201,203,211,213 : 0 - 99999)								0 - 999999			
External Power	DC12V 100mA																			
Reset	External Reset 100ms minimum (Electric/Push Button Reset none)																			
Memory	EEPROM Data retention:10 years minimum 10,000times maximum																			
Consumption (VA)	8.5	9	8.5	9	17	18	17	18	9.5	10	9.5	10	19	20	19	20	10.5		21	
	NO		YES		NO		YES		NO		YES		NO		YES		NO	YES	NO	YES
Free Wright Input	Open Collector Transistor ( L : 2Vmax H : 4 - 30V Sink Current 7mA) or Contact Input(digital switch) Parallel BCD (Positive Logic / Negative Logic)																			
Free Wright Range	0 - 9999 ( but if Minus (-) sign : -9999 - 0 )								0 - 99999 ( but if Minus (-) sign : -99999 - 0 )								0 - 999999			
Operating Temperature	-10 - 50°C (Non-Freezing)																			
Operating Humidity	45 - 85%RH (Non-Freezing)																			
Hi-Pot Test	AC1500V 1minute																			
Dielectric Test	100MΩminimum (DC500V Megger)																			
Noise Immunity	Pulse Wave Noise from Noise Simulator ±2.0KV ( Power Terminals ) ±500V ( Input Terminals )																			
Casing	Coated Metal																			
Case Coating	N1.0(Black) Lasertone																			

ITEM	G86-105	115	205	215	305	315
Display	Red LED 101.6 (H) x 60.0mm (W)					
No.of Digits	4		5		6	
Power	AC100 - 240V -15% / +10% 50/60Hz					
Input	Open Collector Transistor ( L : 2Vmax H : 4 - 30V Sink Current 7mA) or Contact Input (digital switch) Parallel BCD ( Positive Logic/Negative Logic)					
Connection	Input : Terminal Screw Power:Terminal Screw Free Write:Anphenol Connector					
Decimal Point	0.0/0.00/0.000					
Display Range	0 - 9999		0 - 99999		0 - 999999	
Consumption	9VA	18VA	10VA	20VA	11VA	22VA
Operating Temperature	-10 - +50°C ( Non-Freezing)					
Operating Humidity	45 - 85%RH ( Non-Freezing)					
Hi-Pot Test	AC1500V 1minute					
Dielectric Test	100MΩminimum (DC500V Megger)					
Noise Immunity	Pulse Wave Noise from Noise Simulator ±2.0KV ( Power Terminals ) ±500V ( Input Terminals )					
Casing	Coated Metal					
Case Coating	N1.0(Black) Lasertone					

### CAUTION!

- ⚠ Make sure to wait at least 1 minute after disconnecting the power of the unit before touching or making changes to the Terminal Jumper positions.
- ⚠ Make sure that mounting fixtures are installed properly and screws are tightened.
- ⚠ When using Multi Level units, make sure that levels are connected properly and in order.
- ⚠ After completion of settings, make sure that door panels are properly closed and screwed.

# TERMINAL CONNECTIONS

## Input Terminal Arrangement

No.	Connection	No.	Connection
1	1kHz Input Add	6	20Hz Input Add
2	1kHz Input Subtract	7	20Hz Input Subtract
3	+12V	8	Input Selection
4	GND	9	GND
5	Reset	10	Input Inhibit

No.	Connection	No.	Connection
P1	0V	P3	0V
P2	AC100~240V	P4	AC100~240V

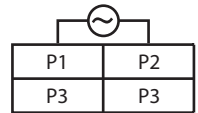

P1 and P3 / P2 and P4 are internally connected.  
If extra terminals for power are needed, please use these terminals.

# WIRING

## [INPUT]

Terminals No.8 is used for selecting the INPUT type.  
If OPEN COLLECTOR INPUT, connect it with Terminal No.3.  
If PNP Non-Contact VOLTAGE INPUT, connect it with Terminal No.9.

### OPEN COLLECTOR INPUT

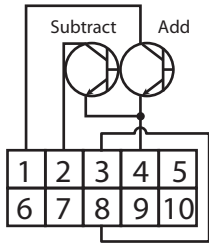

### OPEN COLLECTOR Sensor INPUT

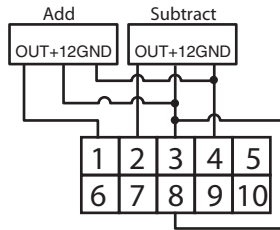

### OPEN COLLECTOR 90°Quadrature INPUT

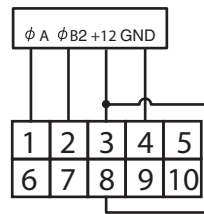

### CONTACT INPUT

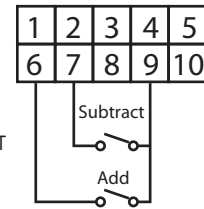

### PNP NON-CONTACT VOLTAGE INPUT

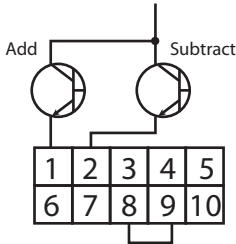

### PNP VOLTAGE OUTPUT Sensor INPUT

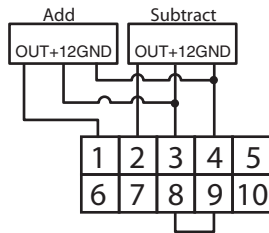

### PNP Voltage Output 90°Quadrature INPUT

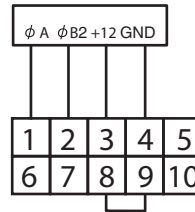

## [RESET & INPUT INHIBIT]

### CONTACT

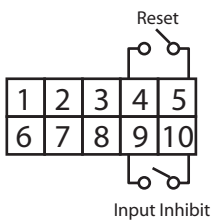

### OPEN COLLECTOR

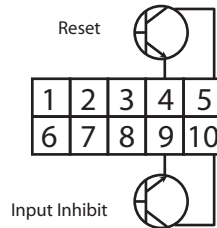

- **RESET**  
Connecting Terminals No.4 and 5, will reset the display.  
Models with Free Write, upon reset, the display will show Free Write set value.
- **INPUT INHIBIT**  
Connecting Terminals No.9 and 10, will cause the counter not to count even if Input signals are inputted.

## [BCD INPUT, DECIMAL POINT AND FLASHING INPUT]

### 36P Amphenol Connector Diagram

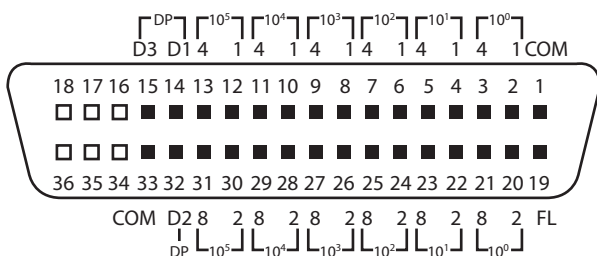

- **BCD INPUT**  
Using signals from an Open Collector source or Contact source (Digital Switch), feed these signals between the Input Terminals and COM (GND).  
10<sup>0</sup> refers to 1st Digit of the data, 10<sup>5</sup> refers to 6th digit, so on so forth.  
For every digit, input the BCD data's 1,2,4 and 8 bits.
- **DECIMAL POINT INPUT**  
To display Decimal Point from an external source signal, connect DP (D1~D3) and COM. D1 is 0.0, D2 is 0.00, D3 is 0.000.  
In this case, set the Terminal Jumpers DP1~DP3 to OPEN state in the internal PCB. (Refer to INITIALIZATION part)
- **FLASHING INPUT**  
Connecting Terminals FL and COM will cause the display to switch On and Off. This can be used to indicate alarm. (Display alarm only)

<"FLASHING" uses>  
\* to show counting  
\* to indicate Alarm when down  
\* to show target value

## ■ MOUNTING (Single Unit)

### ● Suspended/ Hanging Mounting (Standard Type)

Use the metal fixtures and accessories included in the package to mount the unit.

Attach the Brackets (x2) on top of the unit on both sides (as shown in Fig. 3) using the M8 Hexagon Bolts and Spring Washers (x6).

### ● Wall Mounting (Optional Type)

Metal fixtures and accessories for wall mounting are optional parts. If wall mounting is preferred, please inquire for the optional parts.

#### Contents:

1. Brackets .....	2	5. Rubber Bushing .....	1
2. M8 Hexagon Bolt .....	6	6. Nylon Bushing .....	1
3. Spring Washer .....	6	7. Amphenol Connector (Free Write models ) .....	1
4. Allen Wrench .....	1	8. Instruction Manual .....	1

## ■ MOUNTING (Multi-Level Type)

### ● How to link the Case

Linking the case of multiple units can be done thru the multi-level connection holes ( $\phi 12.5$ ) which can be found on top and bottom of the case of each unit. Use an optional M12 Hex Nut & Bolt, Spring and Flat washers to connect the units. Bolt the units together as described in Fig. 3 shown below.

### ● How to link the Power

Linking the power of multiple units can be done thru the power cord holes ( $\phi 15$ ) which can be found on top and bottom of each case. Insert the power cords (optional) thru these holes. Make sure to place the Rubber Bushing first before inserting the power cords. Refer to Fig.3.

Connect external power cord to P1 & P2 of the 1st level unit. Then, connect another set of power cords to P3 & P4 of 1st level unit to the P1 & P2 of the 2nd level unit. Do the same for succeeding level units. Refer to Fig.4.

### ● Inputting same BCD data to multiple units at the same time (2 x Display only or 1 x Display and 1 x Counter)

Feed the BCD data to the first level unit using an external BCD cable. Then link the first level unit to the second level unit using the Free Write Link Data Cable (optional) as shown in Figure 4 below.

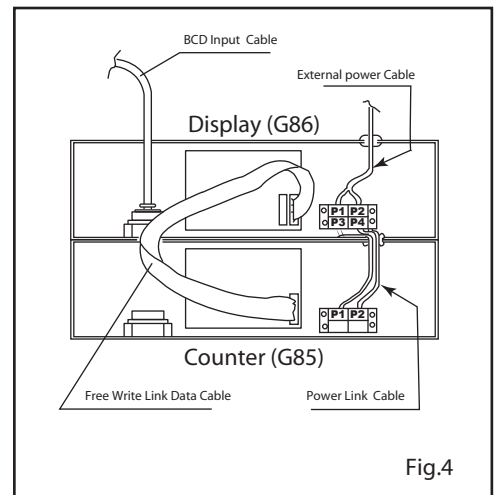
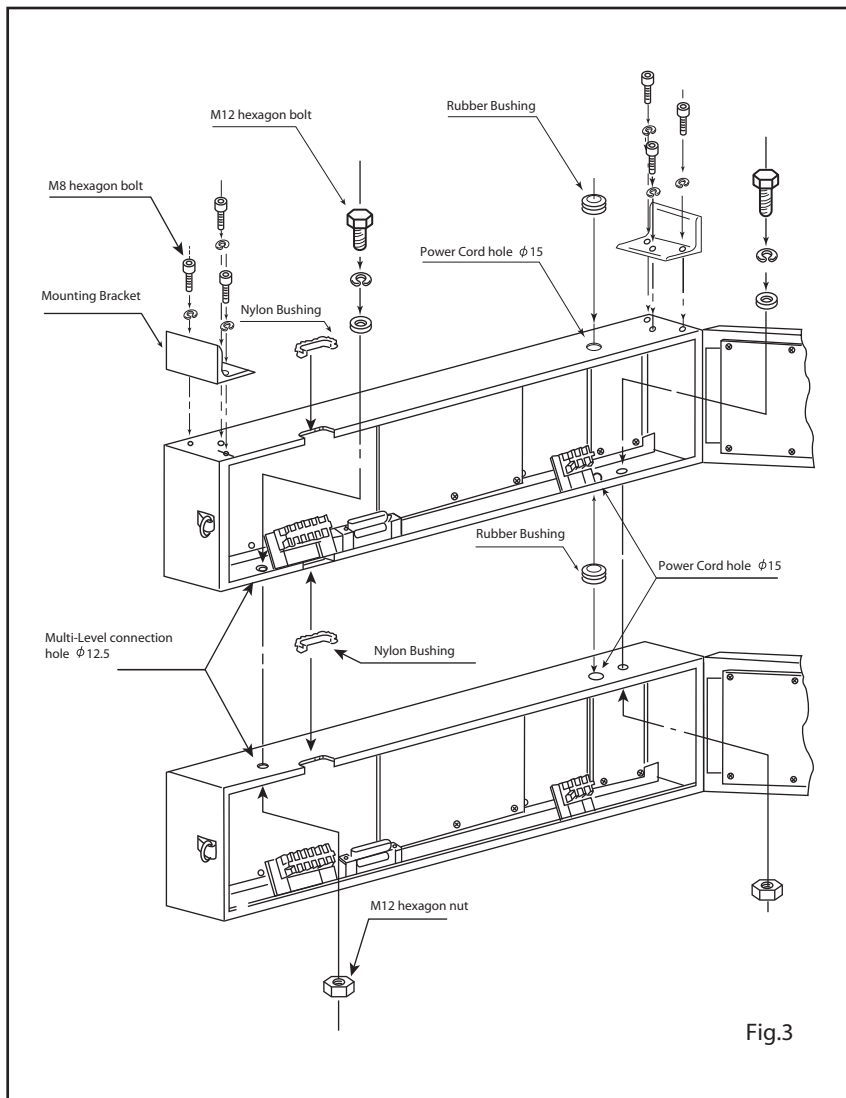

## MODEL SELECTION

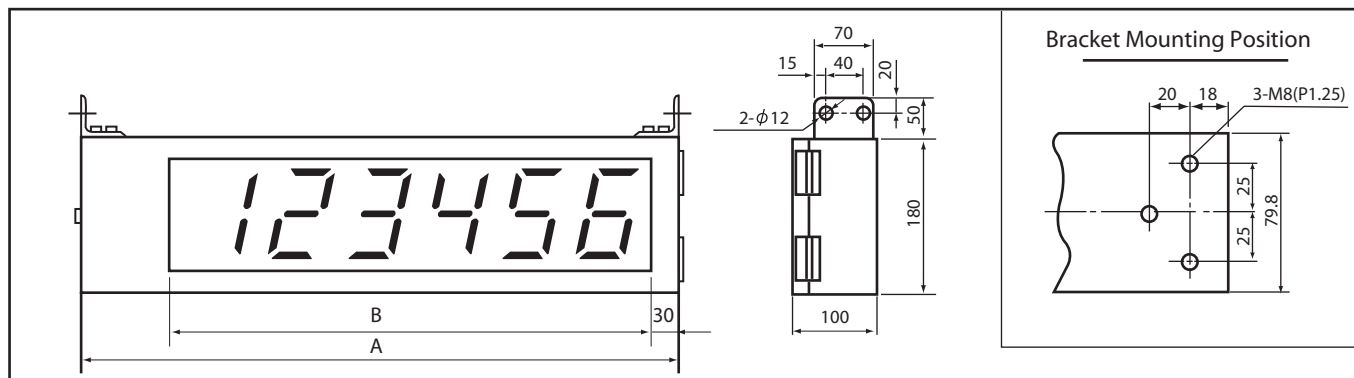

**● Sizes**

Case	S	S	S	L	L
No. of Digits	4	4 with Minus sign	5	5 with Minus sign	6
Symbol	A	589	589	680	680
	B	460	460	551	551

Height Dimensions for Multi-Level Type:  
 Suspended/Hanging Mount = 50+(180xNo. of Levels)  
 Wall Mount = 75+(180xNo. of Levels)

**● Wall Mount Type**

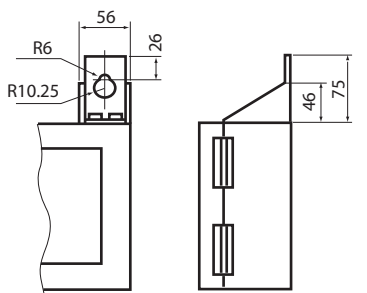

## OPTIONAL PARTS (Sold Separately)

**● TITLE LABELS (Level Titles)**  
 Character Size: 60 x 60mm

1	2	3	4	5	6	7	8	9	10
PLAN	TARGET	EXPECTED	ACTUAL	NUMBER	CURRENT	PROGRESS	DIFFERENCE	ACCUMULATED	RESULTS

\*Special characters are also available. please inquire.

**● Multi-Level Linking Set (for 1 Level set)**

M12 Hexagon Bolt	2	M12 Flat Washer	2	M12 Spring Washer	2
M12 Nut	2	Power Cable	1		

\*These parts are necessary for linking Multi-Level units.

**● Free Write Link Data Cable (1.2m)**  
 \*This cable is used to link Free Write date for multiple units.

**● Wall Mount Brackets (Set)**

## SETTING PARTS (Model: PU-06)

The set value on this Digital Switch device will be shown on the display of the unit.

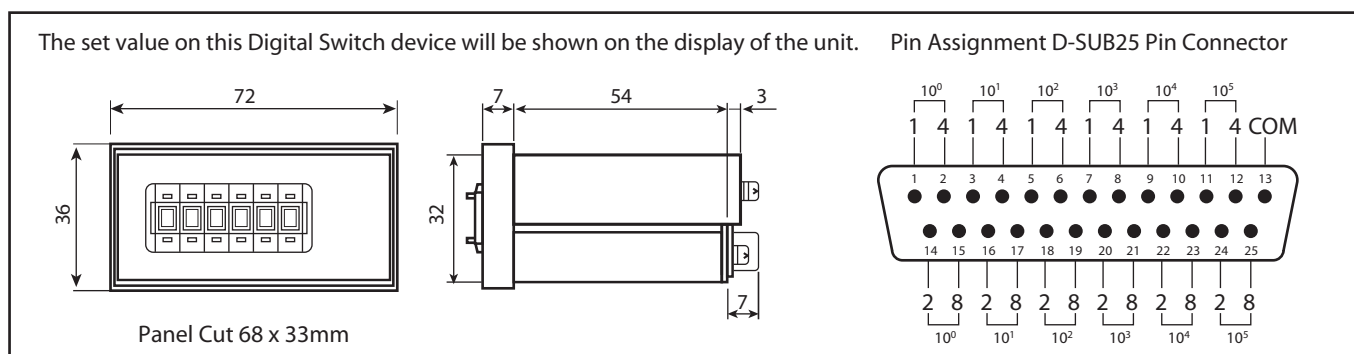

Pin Assignment D-SUB25 Pin Connector

10 <sup>0</sup>	10 <sup>1</sup>	10 <sup>2</sup>	10 <sup>3</sup>	10 <sup>4</sup>	10 <sup>5</sup>	COM						
1 4	1 4	1 4	1 4	1 4	1 4	COM						
1	2	3	4	5	6	7	8	9	10	11	12	13
14	15	16	17	18	19	20	21	22	23	24	25	
2 8	2 8	2 8	2 8	2 8	2 8	2 8						
10 <sup>0</sup>	10 <sup>1</sup>	10 <sup>2</sup>	10 <sup>3</sup>	10 <sup>4</sup>	10 <sup>5</sup>							

\* Specifications Subject to Change Without Prior Notice  
 All Rights Reserved, Copyright © 2007 Line Seiki Co., Ltd.



**LINE SEIKI CO., LTD.**

Address : 37-7, Chuo-Cho, 2-Chome, Meguro-ku  
 Tokyo 152-0001 JAPAN

Contacts : Tel: +81-3-3716-5151 Fax: +81-3-3710-4552  
 E-mail: [webtrade@line.co.jp](mailto:webtrade@line.co.jp)

URL : <http://www.lineseiki.com>