

# G60 Series (Electronic Preset Counter)

## INSTRUCTION MANUAL

- 4 or 6 DIGITS
- 2 LINE RED
- POWER SUPPLY (85 - 264 VAC)
- PRESCALE
- DECIMAL POINT POSITIONING
- DUST / SPLASH PROOF



G60 - 101

G60 - 211

### ■ MODELS

Models	Figures	Preset Level	Input		Prescale
G60-101	4	1	1 Input	Add / Subtract Input	_____
102			2 Input	Quadrature / Individual add, subtract Input	_____
111		2	1 Input	Add / Subtract Input	_____
112			2 Input	Quadrature / Individual add, subtract Input	_____
201	6	1	1 Input	Add / Subtract Input	_____
202			2 Input	Quadrature / Individual add, subtract Input	_____
203			1 Input	Add / Subtract Input	○
204			2 Input	Quadrature / Individual add, subtract Input	○
211		2	1 Input	Add / Subtract Input	_____
212			2 Input	Quadrature / Individual add, subtract Input	_____
213			1 Input	Add / Subtract Input	○
214			2 Input	Quadrature / Individual add, subtract Input	○

### ■ FRONT PANEL AND REAR TERMINALS

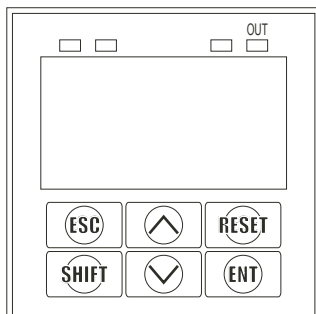

**1 Level Preset**  
G60-101, 102,  
201, 202, 203, 204

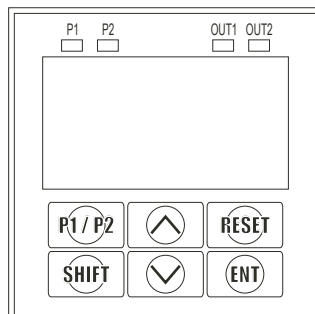

**2 Level Preset**  
G60-111, 112,  
211, 212, 213, 214

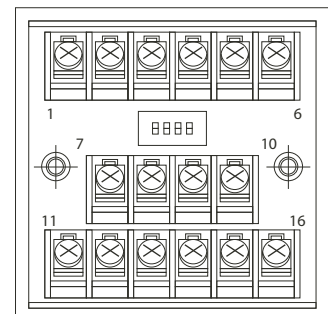

**Rear Terminals**  
Common to all models

**ESC**

Used to exit from the editing mode.  
(1 level preset feature)

**P<sub>1</sub> / P<sub>2</sub>**

Used to select P1 or P2 editing mode, and also used to exit from the editing mode.  
(2 level preset feature)

**SHIFT**

Used to enter the editing mode from count mode, to scroll the editing digit and for decimal point positioning.



Increments the selected digit.



Decrements the selected digit.

**RESET**

Reset present count value to 0. In case sub. input feature, it causes present count value to be reset to the edited value.

**ENT**

Stores the edited value in memory.

## ■ SPECIFICATIONS

Models	G60-101, 102, 201, 202, 203, 204	G60-111, 112, 211, 212, 213, 214
Preset Level	1 preset level	2 preset level
Display	4 digit : Red LED, Count figures : 10.0 x 5.5mm, Editing figures : 8.0 x 4.0mm 6 digit : Red LED, Count figures : 8.0 x 4.0mm, Editing figures : 6.3 x 3.4mm	
Editing Range	4 digit : -999 - 0 - 9999 / 6 digit : -99999 - 0 - 999999	
Prescale	0.0001 - 100 (Multiplier : 0.0001 - 100, Division : 1 - 1/1000)	
Input	1 input type : Add / Sub input (selected by dip-switch) 2 input type : Quad. / Individual add, sub. input (selected by dip-switch)	
Input Method	Non-contact input : Open collector / Contact input : Relay, Microswitch	
Count Speed	Non-contact input : 10 kHz (Prescale feature is 6kHz maximum)* / Contact input : 25 Hz maximum	
Pulse Width	Non-contact input : 5μsec minimum. / Contact input : 20 msec minimum	
Make (Duty)	1:1	
Output	Relay output : N.O. contact only (250 VAC, 0.5A / 30VDC, 2A maximum Load) Non-contact input : NPN open collector (30 VDC, 100mA maximum)	
Output Time	0.1 sec or latch. (In auto-reset mode, output time at the final preset level would be 0.1 sec, even if edited to latch).	
Output Delay	10kHz : 5msec maximum 6 kHz : 30msec maximum (Prescale feature)	
Reset	Front key reset, External reset, Auto-reset	
Inhibition Function	When the Inhibition terminals are turned on, prescale editing, preset editing, front key resetting and counting are disabled.	
Preset Lamp	None	Turns on while each preset value are shown on the display.
Operation Mode	Overrun / Auto-reset	
Decimal Point Positioning	4 digit : 0 / 0.0 / 0.00 / 6 digit : 0 / 0.0 / 0.00 / 0.000 / 0.0000	
Output Lamp	Turns ON during output time	
Memory	E <sup>2</sup> PROM	
Power Source for Sensor	12 VDC 100mA maximum	
Power Source	85 - 264VAC	
Power Consumption	Approximately 5VA	
Operating Temperature	-5 - 50°C (Non-freezing)	
Operating Humidity	45 - 85%RH (Non-condensing)	
Weight	Approximately 230g	Approximately 240g

\* If rotary encoder is used and prescale factor is not used at the counter, maximum count speed should be 10 kHz when the phase of quadrature is  $90^\circ \pm 20^\circ$  and 6kHz when that is  $90^\circ \pm 45^\circ$ .  
If prescale factor is used at the counter, maximum count speed should be 6kHz in any case.

## ■ DIMENSIONS - MILLIMETERS

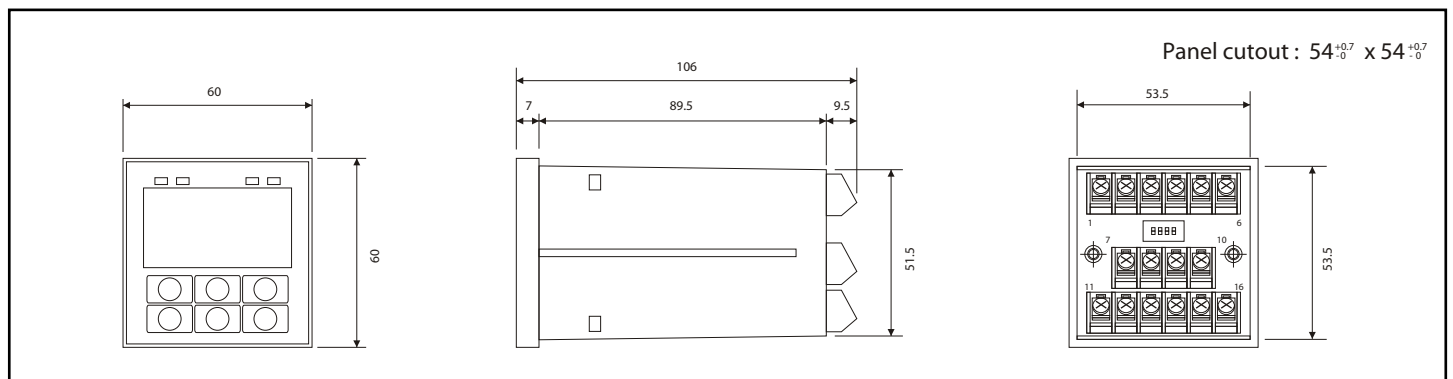

## FEATURES

- **LED**  
2 line display  
By installing count value display and editing value display, edited value can be confirmed at any time.
- **INPUT**  
2 models available, 1 input model which can be selected either add or sub input, and 2 input model which can be selected either quadrature or individual add, sub. input.
- **MINUS (—) character**  
In case input is set to subtract from 0, minus numerical value, -1, -2, -3, appears on the display.  
Also, editing range from -99999 - 0 - 999999 is allowable (6 digit feature).
- **PRESCALE**  
A desired rate for input pulse can be edited, so displayed count value can appear with this desired unit.
- **PRESET**  
Preset value can be edited even if in counting.
- **KEY PROTECTION**  
Key protection terminal causes front key resetting and programming to be inhibited for the protection against mis-operation.
- **INPUT INHIBITION**  
Input inhibition terminal causes coming pulses to be ignored.
- **DECIMAL POINT POSITIONING**  
The decimal point can be lightened at a desired digit by front key operation.
- **POWER SOURCE**  
Allowable range for power source is from 85-264VAC.
- **MEMORY**  
E<sup>2</sup>PROM is installed in all models.
- **COMPACT SIZE**  
Panel size, 60 x 60 mm.
- **DUST / SPLASHPROOF**  
Front panel with flat keys is dust / splashproof.

## DIP - SWITCH

\* Selection of input method, reset method, or output time.

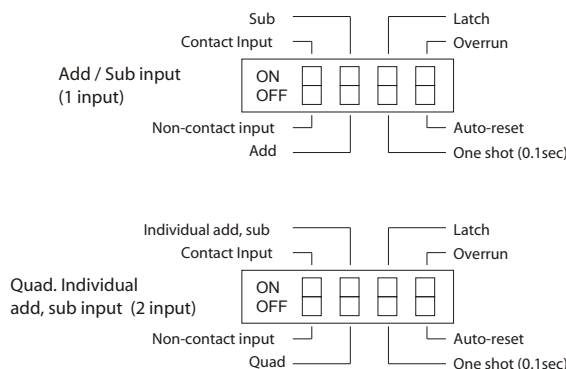

## OPERATIONS

**SHIFT** Pressing **SHIFT** keys causes the most left digit of the editing display to blink.

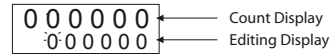

**▲ ▼** Set a desired numerical value on the blinking digit by using **▲ ▼** key.

**SHIFT** Pressing **SHIFT** key further can cause the most left digit to stop blinking and the next digit to blink.

**▲ ▼** Set a desired numerical value on the blinking digit by using **▲ ▼** key.

**ENT** Repeat the above for editing. When editing is completed, press **ENT** key to store the edited value in memory.

※ In case of editing “-” (minus) numerical value, press **▲ ▼** key while **SHIFT** key is pressed. Then, minus “-” character will appear.

※ In case of removing “-” character, press **▲ ▼** key while **SHIFT** key is pressed.

※ In case of exiting from the editing mode, press **ESC** key.

**Preset <2level>**

**P<sub>1</sub>/P<sub>2</sub>** Select either P1 editing or P2 editing by **P<sub>1</sub>/P<sub>2</sub>** key. (Preset lamp for either P1 or P2 will turn on).

**SHIFT** Press **SHIFT** key to enter the editing mode. Repeat same as Preset <1 level>

※ Editing “-” is the same as Preset <1 level>.

※ In case of exiting from the editing mode, press **P<sub>1</sub>/P<sub>2</sub>** key.

**Prescale**

**ENT** Press **SHIFT** key while **ENT** key is pressed and release both keys.

**SHIFT** Press **SHIFT** key within 3 seconds.

**SHIFT** Then the display will enter prescale editing mode and the most left digit will blink.

**▲ ▼** Set a desired numerical value by using **▲ ▼** key. Pressing **SHIFT** key further causes the most left digit to stop blinking, and the next digit to blink

※ Display of prescale editing mode is show below.



Pressing **SHIFT** key scrolls the digit for editing.

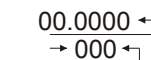

※ For 1 count / 10 pulses set multiplier (x) to 01.0000 and division (÷) to 010.

For 10 counts / 1 pulse, set multiplier (x) to 10.0000 and division (÷) to 001.

※ Multiplier data “00.00000” means 100 and division data “000” means 1,000.

### Decimal Point Positioning

Pressing **SHIFT** key while both **▲** and **▼** key are held to press simultaneously can enter the editing mode for decimal point positioning. Each time pressing **SHIFT** while both **▲** and **▼** key are held to press scrolls the decimal point.

Decimal point position can be decided when both of **▲ ▼** key are released.

# SAMPLE OPERATION

## 1 level preset, overrun mode

(Add / Quad / Individual add, sub input)  
 < Output time : Latch >

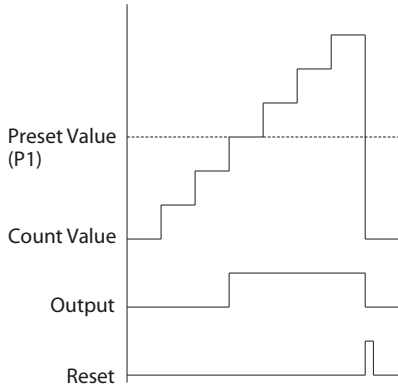

## 1 level preset, auto-reset mode

(Add / Quad / Individual add, sub input)

\* Output time on auto reset mode would be 0.1 sec. even if set to latch

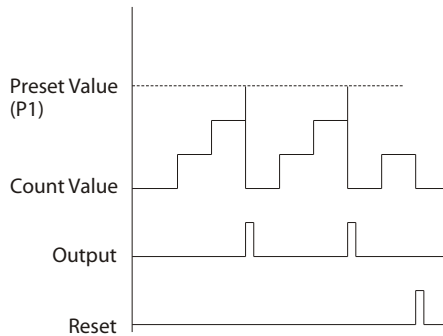

## 1 level preset, auto-reset mode

(Sub input)  
 <Output time : Latch >

\* Subtracts from 1st preset (P1) value and outputs when reaches to 0.

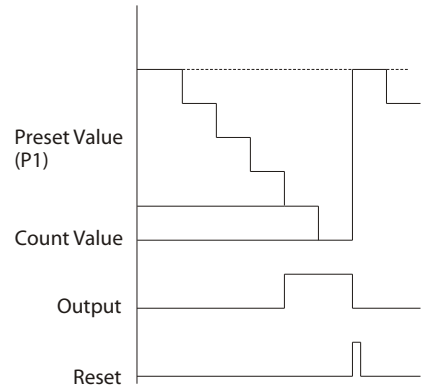

## 2 level preset, overrun mode

(Add / Quad / Individual add, sub input)  
 < Output time : Latch >

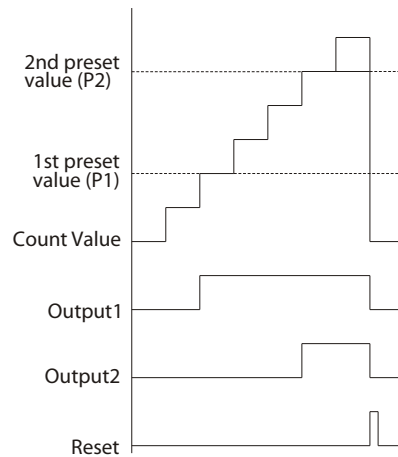

## 2 level preset, auto-reset mode

(Add / Quad / Individual add, sub input)  
 <Output time : Latch >

\* Output time of the final preset level on auto reset mode would be 0.1 sec. even if set to latch

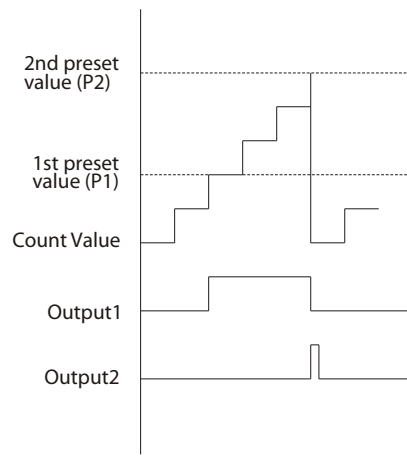

## 2 level preset, overrun mode

(Sub input)  
 <Output time : Latch >

\* Subtracts from 2nd preset (P2) value and outputs when reaches to 0.

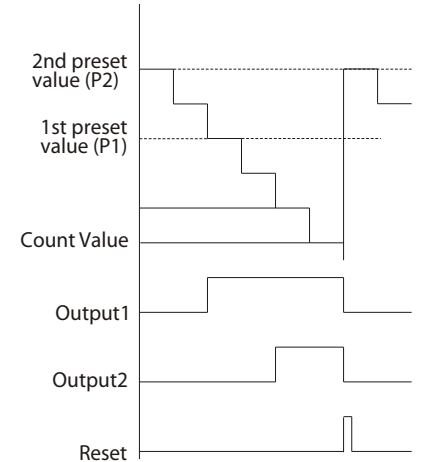

## 2 level preset, overrun mode

(Quad / Individual add, sub input)  
 < Output time : One shot (0.1 sec) >

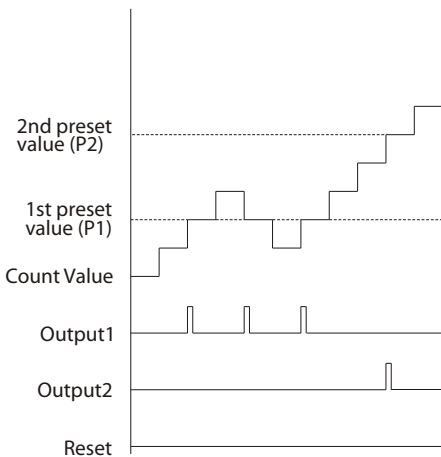

## 2 level preset, auto-reset mode

(Quad / Individual add, sub input)  
 < Output time : One shot (0.1 sec) >

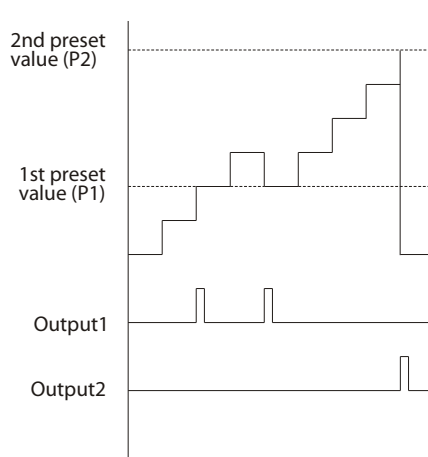



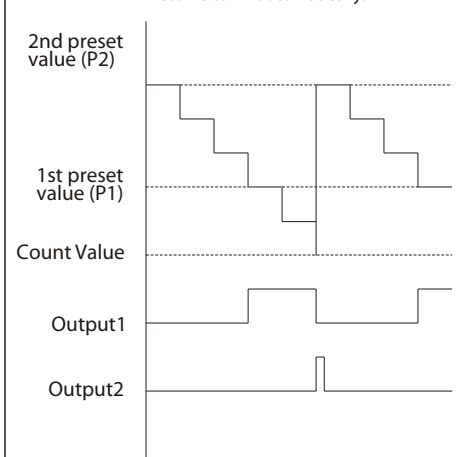

## 2 level preset, auto-reset mode

(Sub input)  
 <Output time : Latch >

\* Subtracts from 2nd preset (P2) value and outputs when reaches to 0. Then, returns to P2 automatically.

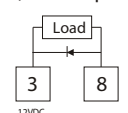
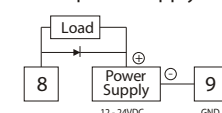

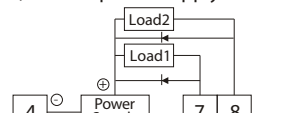
# WIRING

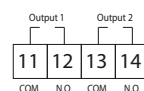
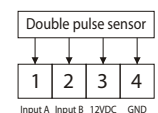
	1 Level Preset		2 Level Preset	
	1 Input (Add / Sub)	2 Input (Quad/Individual add, sub)	1 Input (Add / Sub)	2 Input (Quad/Individual add, sub)
Terminal Locations	No. 1 Input 2 _____ 3 12 VDC 4 GND 5 Reset 6 Input inhibition 7 _____ 8 Open Collector output 9 GND 10 Key Protection 11 _____ 12 _____ 13 COM. } Relay output 14 N. O. } 15 0 VAC } Power Source 16 85 - 264 VAC }	No. 1 Input A 2 Input B 3 12 VDC 4 GND 5 Reset 6 Input inhibition 7 _____ 8 Open Collector output 9 GND 10 Key Protection 11 _____ 12 _____ 13 COM. } Relay output 14 N. O. } 15 0 VAC } Power Source 16 85 - 264 VAC }	No. 1 Input 2 _____ 3 12 VDC 4 GND 5 Reset 6 Input inhibition 7 Open Collector output (P1) 8 Open Collector output (P2) 9 GND 10 Key Protection 11 COM. } Relay output 12 N. O. } Output (P1) 13 COM. } Relay output 14 N. O. } Output (P2) 15 0 VAC } Power Source 16 85 - 264 VAC }	No. 1 Input A 2 Input B 3 12 VDC 4 GND 5 Reset 6 Input inhibition 7 Open Collector output (P1) 8 Open Collector output (P2) 9 GND 10 Key Protection 11 COM. } Relay 12 N. O. } Output (P1) 13 COM. } Relay 14 N. O. } Output (P2) 15 0 VAC } Power Source 16 85 - 264 VAC }
Power Source	Power Source  Supply power source between 85 and 264 VAC to terminal No. 15, 16.			
Input	Add / Sub input (1 input only) <div style="border: 1px solid black; padding: 5px; width: fit-content; margin: 5px auto;">G60-101, 111, 201 203, 211, 213</div> Quad. / Individual add, sub. input (2 input) <div style="border: 1px solid black; padding: 5px; width: fit-content; margin: 5px auto;">G60-102, 112, 202 204, 212, 214</div> Select either add or sub input by dip-switch No. 2. Subtract input to be dip-switch No. 2 ON, and add input to be dip-switch No. 2 OFF. * Turning dip-switch ON / OFF should be done during power off.			
Output	Open Collector output (Internal power supply is used)  Open Collector output (External power supply is used)  Open Collector output (Internal power supply is used)  Open Collector output (External power supply is used)  Relay output  Relay output  Quad. input 			
Inhibition and Protection	Input inhibition ..... Pulses cannot be counted while terminal No. 6 and 9 are shorted. Key protection ..... Prescale, preset values and decimal point position cannot be edited, and front key resetting is inhibited while terminal No. 9 and 10 are shorted.			
Reset	Remote reset ..... Preset count value and output are reset when Terminal No. 4 and 5 are shorted via relay or microswitch. Coming pulses are ignored while terminals are shorted.			



**LINE SEIKI CO., LTD**

37-7, CHUO-CHO, 2-CHOME  
 MEGURO-KU, TOKYO  
 JAPAN 152-0001  
 TEL: +83-3-3716-5151  
 FAX: +83-3-3710-4552  
 E-MAIL: webtrade@line.co.jp  
 URL: <http://www.line-seiki.com>

This manual was last revised Feb.06, 2003.  
 \*Subject to change without prior notice.  
 All Rights Reserved. Copyright © 2003, LINE SEIKI CO., LTD.