

# CT Series (Pulse Generator / Linear Measuring)

## INSTRUCTION MANUAL



# CT

( Switch contact output )

# CT-A

( Photoelectric sensor 1 output )

# CT-R

( Photoelectric sensor 2 outputs bidirectional type )

This device sends out a pulse signal for a meter, 0.1 meter, 1 centimeter, or 1 millimeter when its two measuring wheel are put on running materials such as cloth, paper, belt, metal sheet or plastic film, etc., or when the wheels are put on a roller rotating synchronously with a running material. The linear measurement can be registered on an electric or electronic counter used with this device.

### FEATURES :

This device can be installed at a most suitable place remote from the registering counter. With a preset counter, this device can control accurate cut-to-length or repetitive operations. As this device makes pulses on either rotation, it can be used to totalize the volume of bidirectional movements.

Model	Output	Unit	Speed	Weight	Torque	Proper Counter
CT3:1	Microswitch	1m	400 m/minute	680g	0.015N·m (153gf·cm)	Electronic Counter Electromagnetic Counter
CT3:10		0.1m	40 m/minute	680g		
CT3:1A	Photoelectric Sensor 1 Output	1m	700 m/minute	690g		Electronic Counter
CT3:10A		0.1m	500 m/minute	690g		
CT3:100A		1cm	250 m/minute	690g		
CT3:1000A		1mm	100 m/minute	710g		
CT3:1R		1m	700 m/minute	730g		
CT3:10R	Photoelectric Sensor 2 Outputs ( 90° Quadrature Output )	0.1m	500 m/minute	730g		Bidirectional Electronic Counter
CT3:100R		1cm	250 m/minute	740g		
CT3:1000R		1mm	100 m/minute	740g		
CT3:10000R		0.1mm	35 m/minute	740g		

Option : For heavier duty, ball bearing can be furnished on driving shaft of this device.

B should be added to model number. Ex. CT3:10AB

\* Please order type of measuring wheel. 2 pieces of measuring wheel for meter are equipped as standard accessories. Instead of those, 2 pieces of measuring wheel for yard or 1 piece of grooved wheel for meter are available.

Operating Temperature	-5°C - +40°C	Operating Humidity	85%RH maximum	Remarks	Non-Freezing, Non-Condensing
-----------------------	--------------	--------------------	---------------	---------	------------------------------

## SPECIFICATIONS

MODELS	OUTPUT	POWER SOURCE	CURRENT CONSUMPTION	OUTPUT IMPEDANCE	MAXIMUM LOAD CURRENT
CT3:1, 3:10	1 Output	Microswitch, Capacity : AC250V · 10A $\cos \phi = 1$			
CT3:1A, 10A, 100A	1 Output	DC 5 - 24V $\pm 10\%$	35 mA	3.9KW	100 mA
CT3:1000A	1 Output	DC 5 - 12V $\pm 10\%$	20 mA	2KW	20 mA
CT3:1R, 10R, 100R	2 Outputs (90° Quadrature)	DC 5 - 24V $\pm 10\%$	70 mA	3.9KW	100 mA
CT3:1000R	2 Outputs (90° Quadrature)	DC 5 - 12V $\pm 10\%$	40 mA	2KW	20 mA

## COMBINATION OF THE PULSE GENERATOR AND COUNTER

Select the most suitable counter to the pulse generator in accordance with measuring unit, speed or application

- For total numerical value  
Use Model: CT with an electric totalizing counter or with one of our electronic totalizing counter (size of figures -14.22 x 8.13mm)  
If larger reading is required.  
Use Model: CT-A with an electronic totalizing counter on high speed application.
- Cut-to-length control  
Use Model: CT with a predetermining electric counter to control cut-to-length. On high speed and hard operations, a predetermining electronic counter should be used with Model: CT-A.
- Repetitive operation control  
To repeatedly put a marking at a specified length on running material or to control such very frequently repeated operations, use Model: CT-A with a predetermining electronic counter.
- Bidirectional measuring and control  
Use Model: CT-R with a bidirectional totalizing electronic counter or a bidirectional predetermining electronic counter.

\* On measuring short length, the following should be noted.  
ON and OFF ratio of output contact of this device is 1:1. For example, 0.5m-ON and 0.5m-OFF are for the measuring unit of a meter. Precisely there may be some difference between measured value on the counter and actual length of the material. Namely, the difference may be created with the measuring "start position" or the measuring "stop position" to be made shortly after or before ON/OFF of the output contact has been made. Therefore, it is recommended that you see the device for the measuring unit of 1 cm or 1 mm with an electronic counter in order to measure short length accurately.

## CONNECTION

- Model : CT (microswitch contact output)

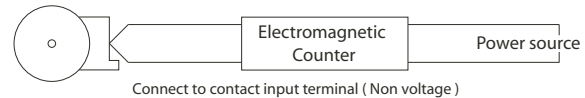
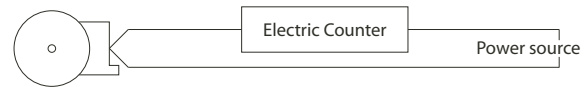

- Model : CT-A (Photoelectric sensor 1 output)

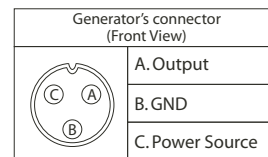
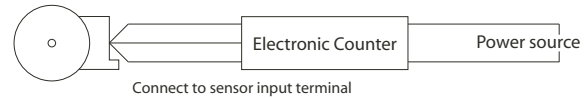

- Model : CT-R (Photoelectric sensor 2 outputs bidirectional type)

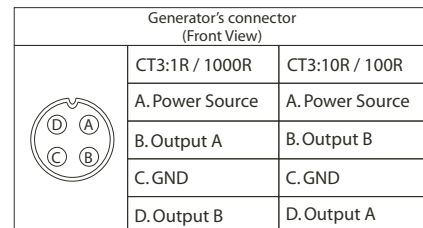
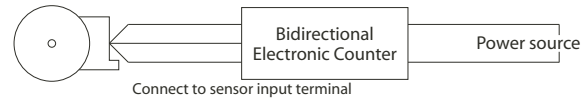

## DIMENSIONS - MILLIMETERS

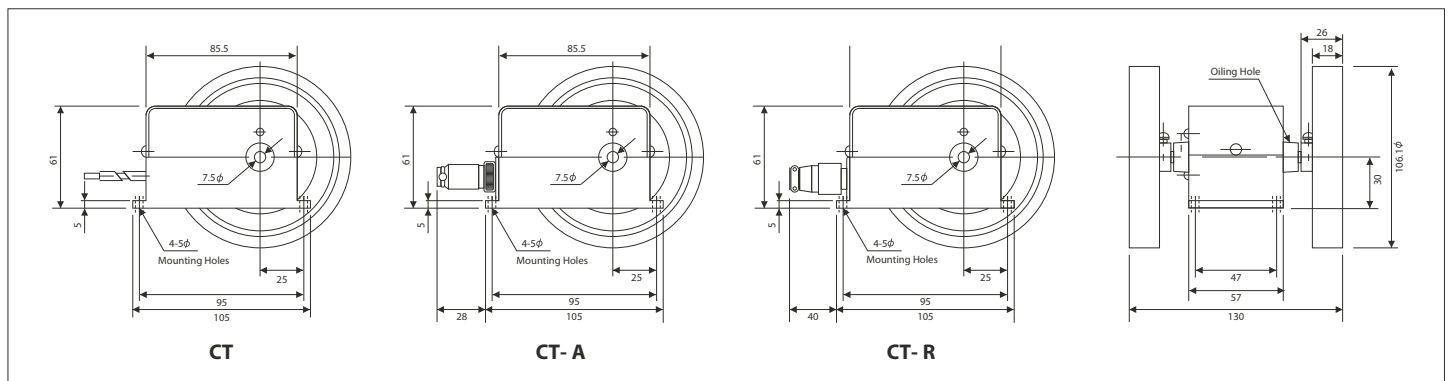

**LINE SEIKI CO., LTD**

37-7, CHUO-CHO, 2-CHOME  
MEGURO-KU, TOKYO  
JAPAN 152-0001  
TEL: +83-3-3716-5151  
FAX: +83-3-3710-4552  
E-MAIL: webtrade@line.co.jp  
URL: <http://www.lineiseiki.com>

This manual was last revised Mar. 29, 2010.  
\*Subject to change without prior notice.  
All Rights Reserved, Copyright © 2010, LINE SEIKI CO., LTD.